

---

# TREATMENT OF PHOSPHATE FERTILIZER PLANT WASTE WATER IN FLORIDA FOR DISCHARGE AND RE-USE PURPOSES

JOHN F. BOSSLER, SIEMENS Water Technologies Corp., Hoffman Estates, IL  
RONALD TRAVIS, SIEMENS Water Technologies Corp., Jacksonville, FL  
CLARKE VEACH, SIEMENS Water Technologies Corp., Dallas, TX  
DOUGLAS M. SPOLARICH, SIEMENS Water Technologies Corp., Parrish, FL

## Abstract

Maintaining a negative water balance in phosphate gyp-stack water is critical to both operating phosphate plants and in sites in the process of closure. This is particularly true in Florida where excessive rain from tropical storms can lead to rapidly rising gyp stack water levels and could result in significant environmental issues.

Siemens Water Technologies has developed, installed and is operating membrane processes that are treating this pond water. The process is producing water that is being discharged directly to the environment. The treated water is generally of better quality than many Florida surface and well water supplies. It can be used in the operating phosphate plants as an alternative source of process water, reducing the need for other sources of fresh water and ultimately reducing the amount of water that has to be treated before being discharged.

The reject from the process can also be recycled to the operating plant for the recovery of the  $P_2O_5$  and acid values or it can be used to reduce the hydraulic load on a subsequent precipitation process.

The composition of all streams as well as the economics of the process will be presented.

## Background

The production of phosphoric acid by the "wet process" involves the reaction of phosphate ore with sulfuric acid. Due to the high purity of the ore, up to 70%  $Ca_3(PO_4)_2$ , central Florida is one of the world's major sources of phosphate rock and phosphoric acid. Approximately 10 billion tons have been excavated from central Florida since 1910 and current reserves are expected to last at least several more decades.

During the manufacturing of phosphoric acid, large amounts of calcium phosphate or phosphogypsum material are produced. For each ton of phosphoric acid produced, approximately 4.5 tons of phosphogypsum is produced. It is slurried with hot acidic process water and disposed of on site, creating what is known locally as "gyp-stacks". The phosphogypsum is required by the USEPA to be stored on site in a stack and it is not permitted to be disposed of off site or used in construction materials such as wall board or road base.

The process water is sequestered for cooling on top of the gyp-stack as well as in ponds and ditches adjacent to it. Due to the impurities in the ore and low pH, the process water contains a high concentration of metals that cannot be discharged to the environment, but in an operating plant, can be returned to the plant for reuse and recovery of acid values.

Normally an active processing plant is operated with negative water balance due to the exothermic reaction of the phosphate ore with the sulfuric acid. The excess heat induces evaporation of the pond water. In the event of excessive rainfall, or in a non operating plant, the water cannot be recycled to the

plant, and evaporation is significantly reduced due to lack of heat input. This puts the plant in a positive water balance, which if not managed properly, can lead to a catastrophic over flow of the gyp stack contained ponds.

**Figure 1: Typical ranges of Gyp Stack pond water in Florida operating phosphate fertilizer plants.**

<b>PARAMETER</b>	<b>UNIT</b>	<b>A</b>	<b>B</b>	<b>C</b>
conductivity	µs/CM	15700	22400	20100
turbidity	NTU	19.3	19.8	46
TOC	ppm as C	107	153	103
pH	Std. Units (0-14)	1.7	1.63	1.62
TOTAL hardness	ppm as CaCO <sub>3</sub>	4420	3798	3593
calcium	ppm as Ca	1410	1122	1102
magnesium	ppm as Mg	219	241	204
sodium	ppm as Na	2411	2373	2138
potassium	ppm as K	357	344	305
Mineral Acidity	ppm as CaCO <sub>3</sub>	16400	16500	14500
Total Acidity	ppm as CaCO <sub>3</sub>	31000	32000	27500
aluminum	ppm as Al	100	97.4	110
barium	ppm as Ba	0.256	0.290	0.250
iron	ppm as Fe	130	121	144
manganese	ppm as Mn	14.3	14	14.6
copper	ppm as Cu	0.316	0.100	0.100
strontium	ppm as Sr	33	30.9	28
zinc	ppm as Zn	4.29	6.32	11
Nessler's NH <sub>3</sub>	ppm	456	1159	785
bicarbonate	ppm as HCO <sub>3</sub>	0.6	0.6	0.6
chloride	ppm as Cl	240	476	55
fluoride	ppm as F	5647	6801	5396
nitrate	ppm as NO <sub>3</sub>	1.2	24.8	24.8
phosphate	ppm as PO <sub>4</sub>	19934	21977	14693
phosphorus	ppm as P	6645	7326	4898
sulfate	ppm as SO <sub>4</sub>	4687	4678	5888
Free CO <sub>2</sub>	ppm as CO <sub>2</sub>	0.0	0.0	0.0
total silica	ppm as SiO <sub>2</sub>	2471	2932	3052

The problem is even more severe in phosphoric acid plants that have been abandoned. Usually there are not even rudimentary treatment systems on these sites, there is little if any capital available for cleanup and the location of the pond is in an environmentally sensitive area.

**Figure 2: A typical analysis of pond water at an abandoned plant in Florida.**

<b>Parameter</b>	<b>Units</b>	<b>2002 Process Water Values</b>
Color	PCU	70
Fluoride	Mg/L	170
Calcium	Mg/L	591
Phosphorous as P	Mg/l	1600
Ammonia	Mg/l	700
pH	Units	2.85
Silica	Mg/L	210
Sulfate	Mg/L	4600
Conductivity	µs/cm	10,500
Total Nitrogen	Mg/l	730
TOC	Mg/L	72
Turbidity	NTU	15

Compounding this problem, most of the existing phosphogypsum stacks were not constructed over a liner and have significantly contaminated the adjacent ground water. This issue was addressed by the FDEP in 1993 and was subsequently amended, which established critical safety standard including lining of all new ponds with HDPE.

In Florida there are currently 24 phosphogypsum stacks, covering nearly 8000 acres and containing an estimated 1.2 billion tons of phosphogypsum and more than 50 billion gallons of nutrient rich, acidic process water. All of this water will have to be treated before a phosphoric acid plant can be permanently closed.

#### **Waste Water Treatment Options**

- Evaporation
- Double Liming
- Double Liming followed by Reverse Osmosis
- Hauling Water off site
- Deep Well Injection
- Reverse Osmosis

---

Numerous treatment options can be used to reduce the contamination in pond water to facilitate reuse or discharge. These options include evaporation, single or double liming, deep well injection and membrane (Reverse Osmosis) systems. Each option has advantages and limitation depending on the site and discharge quality requirements. It is the purpose of this paper to concentrate on the use of Reverse Osmosis membrane treatment technologies.

### **Reverse Osmosis**

Siemens has employed reverse osmosis systems with excellent results on abandoned sites, non-operating phosphate plants and plants currently in operation.

Reverse Osmosis has significant advantages over other technologies. These include:

- Excellent product water quality, usually better than receiving streams for discharge or most Florida ground waters, for other plant process use such as cooling tower or boiler make-up.
- Minimal chemical usage and solid waste generation when compared to precipitation techniques.
- No loss of phosphate and acid values in reject stream, making recovery possible.

Limitations of reverse osmosis include the need for pretreatment that will reduce turbidity to <1 NTU, and a thorough understanding of the effects that temperature, concentration and pH have on the solubility of sparingly soluble salts. Scaling of these salts on both membrane surfaces and interconnecting piping can be a major operating problem if the system is not operated in a fairly narrow range of these variables. The rejection of various species by the membranes is a function of ionic species present, which is often a function of pH.

Siemens has done a considerable amount of work understanding these variables and has demonstrated the ability to maintain the operating parameters within the operating ranges that optimize both rejection and minimize membrane scaling.

### **Abandoned Site**

The Piney Point fertilizer plant in Palmetto, Florida, has been one of the most publicized environmental cleanup projects, and potentially one of the greatest threats to the Florida environment, during the past decade. Inactive since 1999, and managed by the state of Florida since 2001 after Piney Point's parent company declared bankruptcy, the plant used millions of gallons of water in producing phosphoric acid and solid phosphate and ammonium phosphate fertilizers. When in operation, process water was managed using a series of ponds that acted as the heat sink for plant operations. In an active facility, the heat content of process water is enough to keep the facility in a negative water balance mode where evaporation exceeds rainfall. However, when the plant ceased operation, the water balance was reversed, as more water is collected from rainfall than is evaporated. Without development of a water treatment and discharge/offsite transfer plan, these ponds would have overflowed, and the highly acidic, nutrient-laden process water would have reached Tampa Bay.

Fearing a disaster, the state organized a team to manage the site, and selected wastewater treatment and offsite disposal methods to solve the problem. One of the solutions chosen was reverse osmosis (RO). Mobile RO equipment treated approximately 800,000 gallons/day from ponds that once contained over 800 million gallons of toxic wastewater, making it pure enough to discharge into the bay without adverse impacts.

In pond waters, it has been observed that at pH values of about 2.5 or higher, algae becomes an issue. Below this pH, algae is generally not a problem. Figure 3 shows the process flow of a temporary system installed at Piney Point, an abandoned site that was under remediation by a court appointed receiver. This 500-gpm system included 400,000 gallon storage, bentonite clay feed, ballasted clarification to remove the bulk of the suspended solids, dual stage media filtration for fine suspended solids removal and two pass RO with inter-stage pH adjustment and anti-scalant. The pH adjustment is for ammonia removal and the anti-scalant controls precipitation on the second pass membranes caused by the decreased solubility of some salts when the pH is increased. The final step in the process is ion exchange resin that polishes the second pass product to remove low levels of ammonia. Although the membrane process was capable of achieving the discharge specification of < 1PPM ammonia, the practical limit of the process was about 0.7 PPM. As there was no retention between the system and discharge directly to Bishops Harbor, it was felt that a polishing step to prevent an accidental discharge of ammonia directly to the environment was appropriate.

**Figure 3: Piney Point Process Flow Diagram**

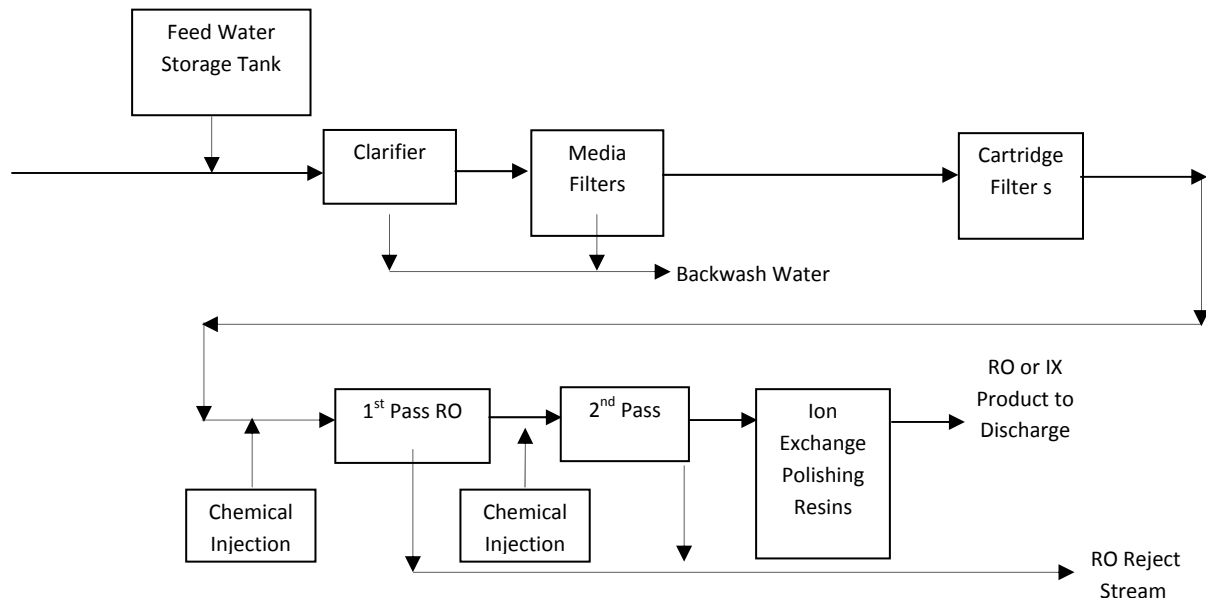

It should also be noted that the final product water was pure enough to pose some toxicity problems, and a small amount of ground water was added to the product before final discharge. The water would have made excellent boiler feed but there were no operating boilers on the site and the temporary nature of the project precluded using the water at a different location.

This equipment started up in May 2002 and operated with numerous changes in operating conditions until May of 2005. Over 500 million gallons was discharged over this period with no significant product quality excursions. A maximum of 800,000 gallons per day was discharged until the site started to run out of feed water.

**Figure 4: 2002 analysis of the raw feed and product water at Piney Point compared to discharge specification.**

Parameter	Units	2002 Feed Water	RO Effluent	Contract Specifications
Color	PCU	70	NA	NA
Fluoride	Mg/L	170	<2	<5
Calcium	Mg/L	591	<0.5	NA
Phosphorous as P	Mg/l	1600	<0.2	<0.5
Ammonia	Mg/l	700	<1.0	<0.9
pH	Units	2.85	6.0-8.5	6.0-8.5
Silica	Mg/L	210	<0.5	NA
Sulfate	Mg/L	4600	<1.0	NA
Conductivity	µs/cm	10,500	<25	<50
Total Nitrogen	Mg/l	730	<1.0	<2.0
TOC	Mg/L	72	<1.0	NA
Turbidity	NTU	15	<1.0	NA
Suspended Solids	Mg/L	24		NA
BOD	Mg/L	17	<1.0	NA

### Operating Plants

Operating plants have an advantage in that they can operate at a negative water balance since they have the ability to reduce gyp stack water through evaporation. The warmer temperature of the water in an operating plant offers the ability to run the RO system at a higher recovery rate, which yields more purified product water that can be discharged to the environment for inventory control, and or used for cooling tower and boiler make-water supplies. The higher rejection rate on the RO also allows for a higher RO reject stream concentration that contains a more concentrated P205 stream that can be recycled into the plant process.

**Figure 5: RO process flow in an operating plant and the multiple uses of the process streams.**

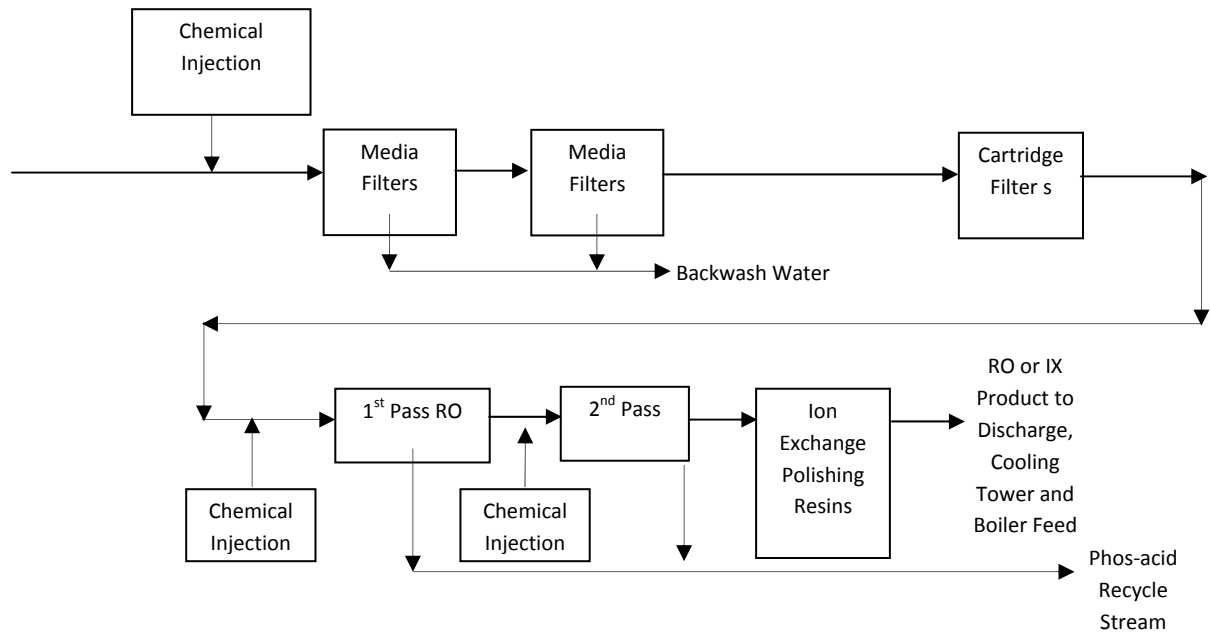

### System Operating Parameters

- For a reverse osmoses system on phosphate pond water feed to be viable, several parameters must be met.
- The recovery of the system must be high enough to be practical
- The rate of membrane fouling must be low enough to permit continuous operation
- Fouled membranes must be able to be cleaned effectively
- The quality of the water produced must meet discharge specifications at minimum cost
- Maintaining minimum operating costs is dependent on a balance of chemical consumption and membrane maintenance

### System Recovery

The higher the system recovery the lower the capital cost per gallon of product. In this two pass system shown in Figure 5, a first pass recovery of 25% to 30% and a second pass recovery of 75% to 80% are typically achieved, with an overall system recovery of 20-24%. In general, the RO recovery rate can be increased with increases in temperature and RO recovery rate must be decreased with increases in feed water Conductivity. It is critical to continuously adjust for changes in these variables since failing to do so will increase the membrane fouling potential and cleaning frequency and decrease membrane life, all of which increase the cost of water production. Fluctuation of these variables will dictate the economic feasibility of the RO water treatment systems at both abandoned and operating phosphate plants.

### Membrane Fouling Suspended Solids

Membrane fouling occurs by two mechanisms, suspended solids and precipitating dissolved solids. The suspended solids are removed by mechanical means. In operating plants, dual stage media with a filter aid addition has shown to be an effective method of reducing turbidity to below 0.1 NTU with a feed of less than 10 NTU. Figure 6 shows Turbidity levels being reduced from 7.21 to 0.6 NTU.

In abandoned sites, the presence of algae at the typically higher pH is more troublesome. The pretreatment, as shown in figure 3, consists of bentonite clay fed to a clarifier along with an oxidation and filter aid addition, followed by dual stage filtration.

**Figure 6: Raw feed Turbidity 7.21 NTU. Top Line -Raw Feed Flow / 2<sup>nd</sup> Line -1<sup>st</sup> Stage MMF Product 3 NTU / 3<sup>rd</sup> Line -2<sup>nd</sup> Stage MMF Product 0.6 NTU.**

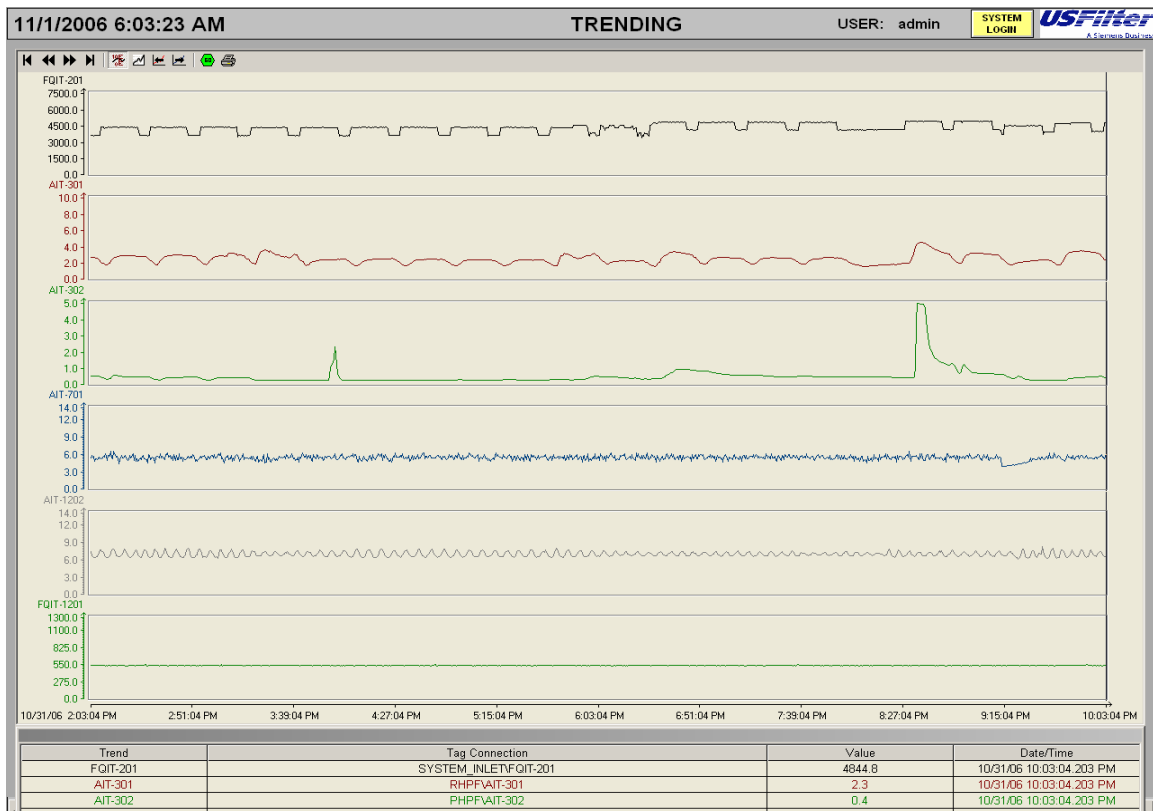

### Membrane Fouling Due to Precipitation

Precipitation of suspended solids is the second mechanism of membrane fouling. The fouling rate of the membranes caused by precipitation is controlled by the TDS, the pH, temperature of the feed and the system recovery. Generally lower TDS, pH, and system recovery and higher temperature result in a lower membrane fouling rate.

Scale on the first pass RO membranes is predominantly fluorosilicic acid and its salts and phosphate salts predominantly calcium. The precipitation of these salts is minimized by maintaining the pH of the feed as low as practical. Figures 8 & 9 show the forms of both fluorosilicic and phosphoric acid as a function of pH.



Figure 7:

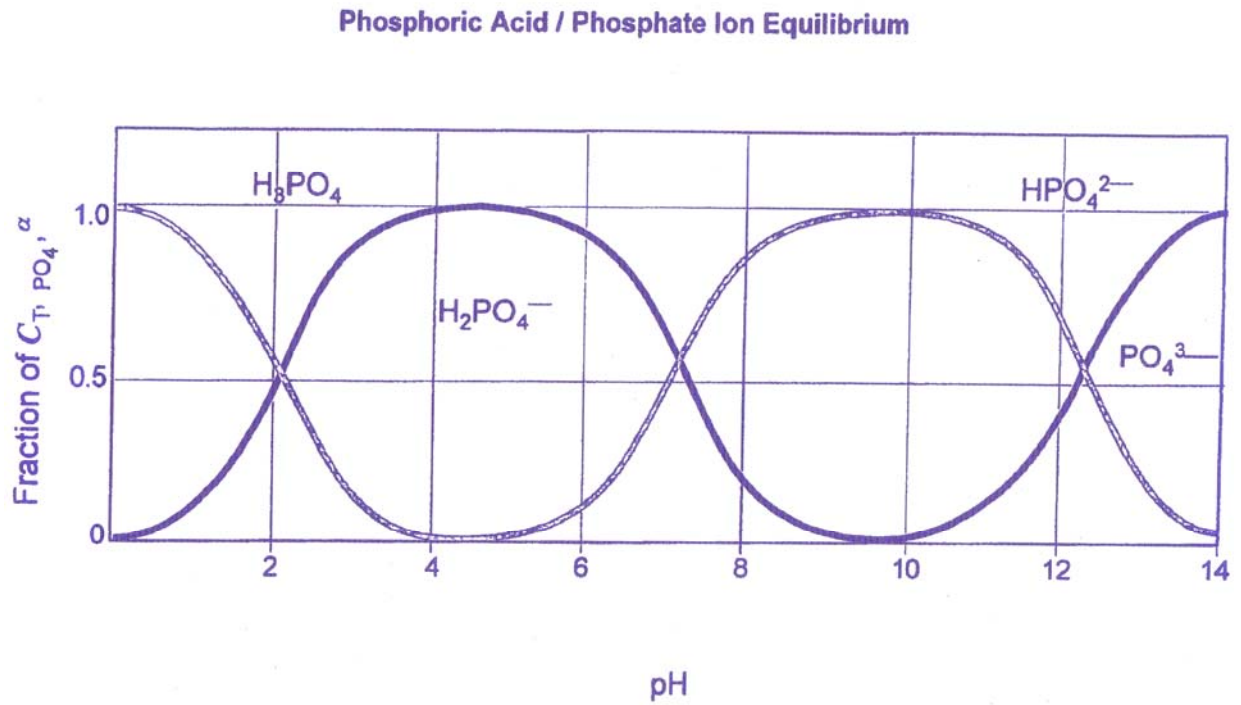
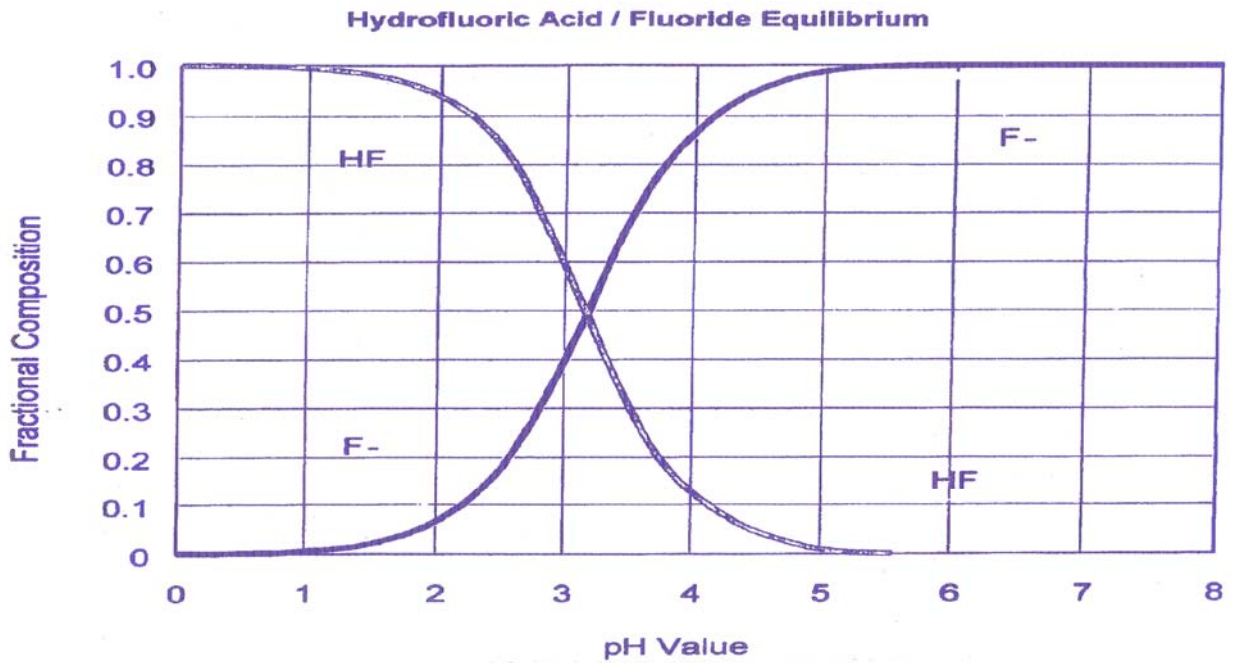

Figure 8:



---

Membranes must be able to be cleaned effectively without damage and loss of rejection. Membrane life must be long enough for limited membrane replacement cost. Although membrane fouling is caused by two distinct mechanisms, they are closely interrelated. Suspended solids will promote precipitation and vice versa. A well controlled program to clean membranes before they are irreversibly fouled is critical. We have established a program where an increase in driving pressure of more than 100 psi or a pressure drop of more than 20 psi indicates a membrane cleaning is needed.

**Figure 9 – RO Membrane fouled with various gyp-stack water precipitated salts.**



**Figure 10: RO Membrane cleaned for re-use.**



**Figure 11: Desired RO membrane cleaning results.**

FilmTec BW30-365 Serial Number	Test	Differential Pressure (psid)	Normalized Results 25 deg C, NDP = 201 psi		Post-Test results outside of USFilter recommended guidelines
			Permeate Flow (gpm)	Salt Rejection	
		< 5	5.6 - 7.6	97.0%	
9258409	Pre	2.8	6.2	85.5%	High Norm. Flow
	Post	1.4	8.2	98.2%	
9353878	Pre	5.0	5.0	93.0%	High Norm. Flow
	Post	3.8	8.7	98.5%	
9258409	Pre	1.2	5.3	96.8%	High Norm. Flow
	Post	1.5	8.9	98.7%	
9353878	Pre	8.0	3.7	93.5%	High Norm. Flow
	Post	5.0	10.1	98.7%	

**RO Product Water Quality as a Function of pH**

Product water quality, specifically fluoride and ammonia, are affected dramatically by the system operating conditions. Reverse osmosis membranes as a general rule have limited ability to reject dissolved gasses. Fluoride exists in solution as hydrofluoric acid at low pH, a dissolved gas, and as a salt at higher pH as shown in Figure 8. Ammonia behaves similarly but in reverse as it is a salt at lower pH and a gas (ammonium hydroxide) at higher pH, as shown in Figure 12. To maintain optimum rejection of both fluoride and ammonia, control of the feed pH to the second pass RO is critical.

**Figure: 12**

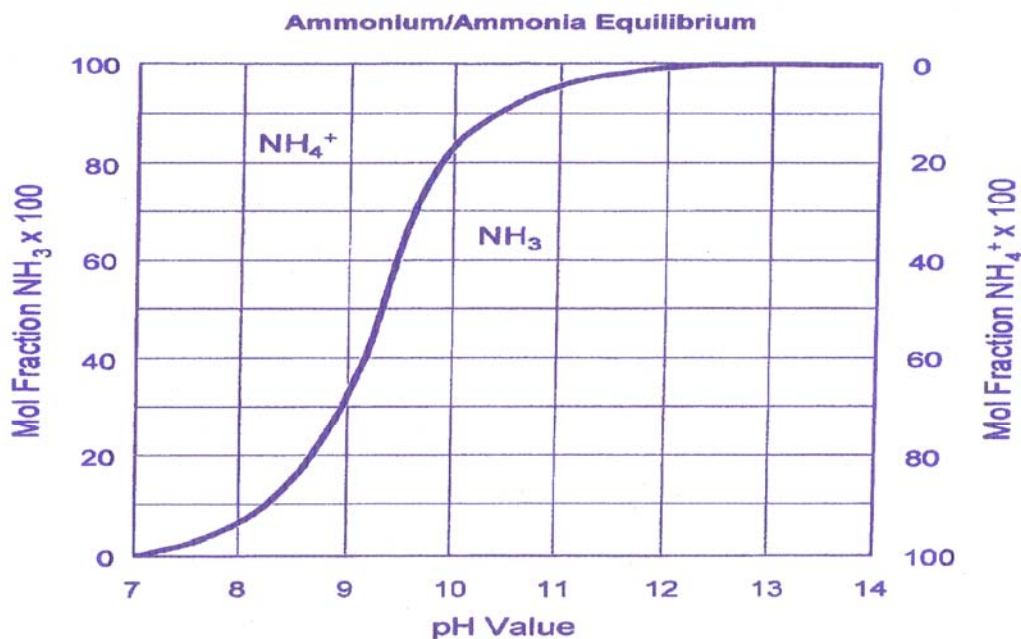

---

## Conclusions

For a successful operation, careful consideration needs to be given to the following:

- Filtration of feed to the RO membranes < 1NTU Turbidity
- Conductivity
- Temperature <110° F
- pH of the feed water can be as low as 1.3
- Clarification may be required at pH above 2.5 if algae is present
- Control of the feed water pH to the second pass RO is critical
- Maintaining minimum operating costs is a function of balancing chemical consumption and maximizing RO membrane life.

Reverse Osmosis membrane technology has shown that it can successfully and economically treat gyp stack pond water with a specific conductivity of up to ~30,000  $\mu\text{S}/\text{cm}$ . Rejection of 99+% of all ionic species can be achieved. The product water can be directly discharged or used for process water and the reject streams can be directed back to the process for acid and phosphate recovery or can be used to reduce the hydraulic load on subsequent precipitation processes.

**Figure 13: Actual raw feed and final system product water quality comparison of water treated by Siemens Water Technologies RO membrane system.**

